

**WORKFORCE INNOVATION & OPPORTUNITY ACT
(WIOA)**

**ARKANSAS
WORKFORCE CONNECTIONS**

A DIVISION OF ARKANSAS DIVISION OF WORKFORCE SERVICES

**ANNUAL
REPORT
PY 2024**



Section	Subsection	Pages
Executive Summary	Introduction	1
<i>Section I</i> State Strategies & Activities	Arkansas' Workforce Development System Vision and Mission Outcomes At-A-Glance Labor Market Information Economic Development and Workforce Development WIOA Title I- Youth, Adult and Dislocated Worker Activities & WIOA Title III- Wagner Peyser Activities Best Practices/Innovation <ul style="list-style-type: none"> • LAUNCH • CIVIFORM • CONNECT • Career Exploration • Business Engagement & Sector Strategies • Data Quality and Reporting • ACT Work Ready Communities 	2-15
<i>Section II</i> Funding	Governor's Reserve/State Set Aside Funds <ul style="list-style-type: none"> • AJL • Technical Assistance Disaster Grant Discretionary Grants <ul style="list-style-type: none"> • USDOE ReImagine Workforce grant 	16-18
<i>Section III</i> Performance Accountability	PY 24 Outcomes Policies <ul style="list-style-type: none"> • Common Exit • Data Validation • Effectiveness in Serving Employers Evaluation/Customer Satisfaction	18-24
<i>Section IV</i> Challenges & Needs	Additional Waivers	24-25
<i>Section V</i> Appendix	Success Stories	

Introduction

Program Year 2024 represented significant progress in operationalizing the [Arkansas Workforce Strategy](#). Building on the foundation described in the PY23 Annual Report, Arkansas meaningfully advanced several strategic initiatives aimed at creating a skills-based, customer-centric, collaborative, and responsive workforce system.

Major accomplishments include the statewide launch of the LAUNCH skills-based learning and employment marketplace, expansion of common intake practices through CiviForm, additional credential registry publishing, national leadership in the Jobs and Employment Data Exchange (JEDx) pilot, sector strategy execution through Talent Pipeline Management (TPM) for Arkansas' emerging lithium industry, and a major federal investment through the Workforce Data Quality Initiative (WDQI) Round 10 award.

Workforce Connections and its WIOA partners advanced a unified approach to service delivery, strengthened collaboration across agencies, and expanded access to training and employment opportunities for Arkansans statewide.

During PY 2024, WIOA Title I (Adult, Dislocated Worker, and Youth), Title II (Adult Education), Title III (Wagner–Peysner Employment Services), and Title IV (Vocational Rehabilitation) programs continued to deliver coordinated services designed to meet the evolving needs of Arkansas's workforce. The year focused on strengthening integration across programs, improving customer experience, and using shared data to guide decision-making and improve outcomes for students, workers, and employers.

These efforts continued the implementation of the **Arkansas Workforce Strategy**, which serves as a statewide framework for aligning education, workforce development, and industry needs. The strategy centers on four guiding themes that shaped program activities throughout PY 2024:



Through these guiding principles, Arkansas continued to focus on creating a workforce system that is modern, aligned, and capable of supporting long-term economic growth.

PY 2024 emphasized implementation, refinement, and operational alignment as agencies worked together to expand opportunities for Arkansans and strengthen connections between education, training, and employment.

STATE STRATEGIES & ACTIVITIES

The Arkansas Workforce Development Board remained a key partner in guiding statewide workforce efforts. Business and community leaders contributed expertise in planning, evaluating, and strengthening workforce initiatives in collaboration with Arkansas Workforce Connections and combined plan partners. Their leadership supports the state's broader goals of increasing participation in the workforce, expanding skill development, and ensuring employers have access to a qualified talent pool.

Vision

Arkansas will have a world-class workforce that is well educated, skilled, and working in order to keep Arkansas's economy competitive in the global marketplace.

Mission

To promote and support a talent development system in Arkansas that offers employers, individuals, and communities the opportunity to achieve and sustain economic prosperity.



Strategic Goal 1: Develop an efficient partnership with employers, the educational system, workforce development partners, and community-based organizations to deliver a platform that will prepare a skilled workforce for existing and new employers

Strategic Goal 2: Enhance service delivery to employers and jobseekers.

Strategic Goal 3: Increase awareness of the State's Talent Development System.

Strategic Goal 4: Address Skills Gaps



OFFICE OF EMPLOYMENT & TRAINING

23 ARKANSAS WORKFORCE CENTERS



EMPLOYER SERVICES

113,274 EMPLOYER SERVICES PROVIDED

91,987 JOB ORDERS

10,843 EMPLOYER CONTACTS

JOB-SEEKER SERVICES

69,643 JOB SEEKERS SERVED

139,588 ARKANSAS JOBLINK (AJL) REGISTRATIONS

70,349 STAFF-ASSISTED AJL REGISTRATIONS

MOBILE ARKANSAS WORKFORCE CENTERS



WIOA TITLE I PARTICIPANTS SERVED (PY 2024)

674 ADULTS

100 DISLOCATED WORKERS

524 YOUTH

1,298 TOTAL

VETERANS SERVICES

4,380 VETERANS SERVED

3,033 AJL REGISTRATIONS

3,001 STAFF-ASSISTED AJL REGISTRATIONS

167

EVENTS SUPPORTED BY THE MOBILE WORKFORCE CENTERS & STAFF

ADULT EDUCATION

NUMBER OF PARTICIPANTS 11,612

TOTAL NUMBER INDIVIDUALS SERVED 19,344

INDUSTRY RECOGNIZED POST-SECONDARY CREDENTIALS EARNED 1,864

GENERAL SKILLS CERTIFICATES 1,089

WAGE CERTIFICATED EARNED (LEVEL 1 & LEVEL 2) 4,390

2024-2025 NATIONAL OUTCOMES:

- Arkansas ranked number 2 in the nation in Credential Attainment Rate of 76.52%
- Arkansas ranked number 4 in the nation in the GED pass rate of 85% compared to the national average of 74%.

Adult Education provides state and federal grant funding to 35 adult education providers statewide. Adult Education offers services in all 75 counties, including adult basic skills instruction, GED® test preparation, English Language Acquisition, workforce preparation, training programs, family literacy, college and career transition, and workplace classes.



ARKANSAS REHABILITATION SERVICES

10,488

TOTAL INDIVIDUALS SERVED

1,381

OBTAINED COMPETITIVE INTEGRATED EMPLOYMENT

2,112

BUSINESS SERVICES PROVIDED

PY 2024

Arkansas Rehabilitation Services' mission is to prepare Arkansans with disabilities to work and lead productive and independent lives. To achieve its mission, ARS provides various training and career preparation programs. There are 19 field offices across the state serving all 75 counties where individuals can receive assistance with accessibility and training needs that can lead to successful employment.

ARKANSAS LABOR MARKET

The most recent Arkansas Labor Market and Economic Report, produced by the Labor Market Information unit within the Office of Workforce Policy and Innovation, provides an overview of statewide and regional workforce conditions across Arkansas and its 10 Local Workforce Development Areas (LWDAs). The report primarily covers trends from 2020 through 2024, with some data reflecting shorter timeframes based on availability. Short-term projections for industry and occupational change span 2024 to 2026.

Arkansas continued to experience population growth, increasing by 20,622 residents from 2023 to 2024 and adding a total of 76,812 new residents since 2020. Among the 10 LWDAs, Northwest Arkansas showed the strongest growth, gaining 15,761 residents in 2024. Three areas—Eastern, Southeast, and Southwest Arkansas—experienced population declines during the same period.

From 2023 to 2024, the state's labor force expanded by 31,335, while employment grew by 27,373. Labor force and employment trends varied by region. Arkansas ended 2024 with an unemployment rate of 3.5 percent, representing a 2.7 percent improvement since 2020. Unemployment remained relatively steady into 2025, measuring 3.7 percent as of July. Rates fluctuated across all LWDAs throughout early 2025.

Short-term employment projections indicate continued growth in the Arkansas job market, with an estimated increase of 32,743 jobs between 2024 and 2026, representing 2.23 percent growth. Goods-producing industries are projected to add 5,708 jobs, while services-providing industries are expected to add 26,108. Self-employment is also projected to grow by 927 positions, an increase of 0.92 percent.

Jobs requiring a high school diploma or equivalent are forecast to add the largest number of new positions—approximately 10,888—between 2024 and 2026. Occupations typically requiring a bachelor's degree are expected to increase by 9,083 over the same period.

Arkansas' per capita personal income rose to \$58,700 in 2024, although it remained below the national average of \$77,719. More than one million Arkansas workers earned at least \$12 per hour in 2024, with the mean annual wage estimated at \$53,074. Among neighboring states, only Mississippi reported lower overall average hourly and annual wages, while Texas reported the highest.

Economic Development and Workforce Development

Arkansas has seen tremendous economic growth throughout 2024, with job creation announcements across the state and in a wide variety of industries. In 2024, the Arkansas Department of Commerce signed job creation agreements with companies that will lead to a total of 3,957 net, new jobs for Arkansans and a total of \$1,542,245,635 in capital investment in our state. This success can be attributed to our low cost of doing business, favorable regulatory environment, and the strength of our communities. In particular, Arkansas' rural communities

won big this year with projects like Tate Manufacturing in Pocahontas, Provalus in Walnut Ridge, White River Energetics in Des Arc, Weyerhaeuser in Monticello, Wild Pastures in Clinton, and Georgia Pacific in Crossett, just to name a few. The message that Arkansas is a great place to do business is spreading across the globe – we have also seen a number of international companies choose to invest in Arkansas this year including Faymonville Group from Europe and Welspun from India.

In 2024, Arkansas made great strides in the improvement of industrial sites with the award of the first ever Arkansas Site Development Program. This program will provide grant funding to 13 communities around the state to make their industrial sites more competitive for job creation projects.



The “I” in WIOA: Innovation

WIOA Title I- Youth, Adult and Dislocated Worker Activities

WIOA Title III- Wagner Peyser Activities

Arkansas continues to strengthen the “Innovation” in the Workforce Innovation and Opportunity Act (WIOA) by modernizing service delivery, expanding digital access, and developing forward-thinking strategies that help job seekers, employers, and communities adapt to a rapidly changing economy. PY 2024 marked another year of significant progress as statewide partners embraced new tools, technology, and collaborative approaches.



Local Workforce Development Boards continued to demonstrate creativity and responsiveness through community-driven initiatives, including:

- *Hosting financial literacy and credit repair workshops for all participants

- *Incorporating after-hour appointments to provide greater flexibility for customers
- *Participation in “Draft Day” events designed to connect driven high school students with local companies
- *Creating and maintaining virtual career centers/intake portals and digital campaigns targeted for unconventional customers
- *Organizing military-focused and sector-focused job fairs

Innovation in Action: Modernizing Workforce Access & Delivery

Arkansas LAUNCH- Skills-Based Talent Marketplace

In February 2025, Arkansas officially announced the public rollout of LAUNCH for Jobseekers and LAUNCH for Employers, marking a major milestone in the state’s transition to a skills-based, digitally-enabled workforce system . [LAUNCH](#) consolidates functionality previously spread across several systems into a single, user-centered platform accessible on any device.

LAUNCH for Jobseekers provides personalized skills assessments, career exploration tools, skills-based job matching, training and education recommendations (including the Eligible Training Provider List), and a streamlined method for documenting and tracking work search activities. Beginning in January 2025, all Unemployment Insurance (UI) claimants will use LAUNCH, making Arkansas one of the nation’s first states to embed a statewide skills-based navigation tool directly into UI service delivery.

LAUNCH for Employers enables businesses to create skills-based job descriptions, search the talent marketplace for candidates based on skills, credentials, and experience, and send customized invitations to candidates. Employers have equated it as moving from playing defense to playing offense in talent acquisition.

Over one-third of Arkansas school districts have incorporated LAUNCH into career exploration and student success planning. Employers, colleges, and community organizations, including Goodwill Industries of Arkansas, have integrated LAUNCH into their day-to-day operations, demonstrating strong early momentum toward a truly statewide skills-based talent ecosystem.

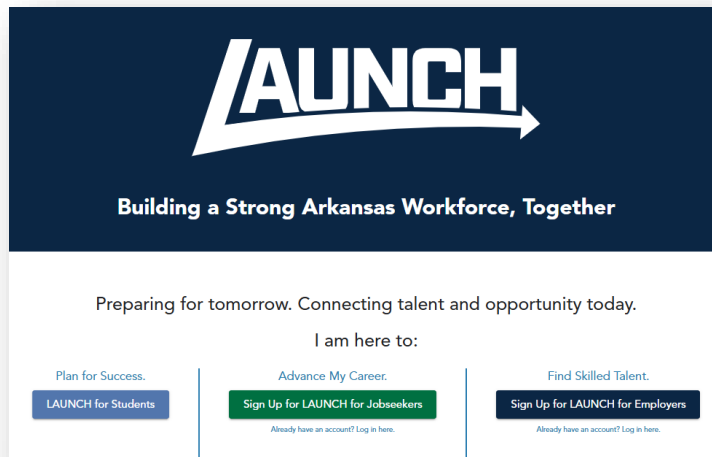

CIVIFORM Integrated Service Delivery and Referral System

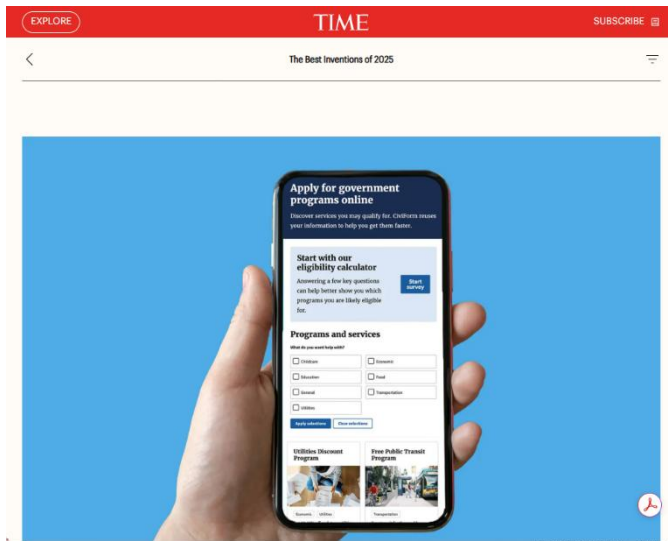

In alignment with [WIOA’s integrated service delivery vision](#) and Arkansas’ “No Wrong Door” service strategy, PY24 saw significant progress in the adoption and expansion of CiviForm, the state’s streamlined service discovery and common intake platform.

[CiviForm](#) grew from its initial implementation in American Job Centers to broader adoption across community colleges, workforce boards, campus student services, community-based organizations, and reentry program partners. Additional state and community-based programs have been added, and the CMS Transforming Maternal Health

(TMaH) grant will add WIC, MIECHV, Healthy Start, SNAP, Medicaid, and Arkansas Be Well Baby to CiviForm.

CiviForm has been included as a key component of multiple state strategies, plans, and federal waivers, and it was recently named one of Time Magazine’s Best Inventions of 2025.

As Arkansas continues its transition toward integrated eligibility and co-enrollment strategies, CiviForm's adoption demonstrates meaningful progress toward a modern, frictionless, and data-driven intake system aligned with WIOA and federal guidance.

CONNECT Call Center – Statewide Virtual Access

**Looking for a job?
or a better job?**
We're here to help!

Can't make it to an office? Take advantage of our **Employment Services Service Center** and receive services by telephone with a live person!

Call today!
MONDAY-FRIDAY
8 A.M.-4 P.M.
1-844-908-2178

Why Choose Us?

- **Expert Guidance:** Our career advisors provide personalized support tailored to your skills and aspirations.
- **Extensive Job Listings:** Access a wide range of job opportunities across various industries.
- **Resume Assistance:** Get help crafting a resume that stands out to potential employers.
- **Interview Preparation:** Receive tips and practice sessions to ace your interviews.

Equal Opportunity Employer/Program. Auxiliary aids and services are available upon request to individuals with disabilities. Voice 1-800-285-1121 TDD 1-800-285-1131 Arkansas's Wagner-Peyser program is 100 percent funded by the U.S. Department of Labor through awards totaling \$4,999,917.

A proud partner of the [America's Job Center](#) network.

In PY 2024, Arkansas launched the “CONNECT” Call Center, a statewide telephone-based access point that expands how job seekers can engage with the public workforce system. CONNECT provides assistance with employment services, referrals, job search support, and questions related to Arkansas JobLink (AJL), ensuring customers can receive help even when they are unable to visit a physical Workforce Center.

From September 2024 through June 2025, CONNECT handled 26,076 calls, reflecting strong early demand and demonstrating the value of a centralized, accessible customer-support model.

CONNECT is built and operated on the same platform used by the Unemployment Insurance (UI) call center, allowing UI claimants to be seamlessly transferred to Employment Services staff for job search assistance, career guidance, and referrals to workforce programs. This integration strengthens Arkansas’s customer-centered service delivery by reducing hand-offs, shortening wait times, and ensuring individuals receive the support they need in a single, streamlined experience.

Career Exploration through Virtual Reality



Arkansas’ Workforce Centers are pioneering the use of virtual reality (VR) headsets to transform career exploration.

Through immersive simulations, job seekers can step into high-demand fields such as healthcare, advanced manufacturing, information technology, and skilled trades—experiencing real-world tasks in safe, engaging environments.

These VR tools empower participants to discover career pathways, build confidence, and make informed choices about training and employment. Employers benefit as well, gaining a pipeline of candidates who have already “tested” their interests and skills in simulated settings. By integrating VR into workforce development, Arkansas is demonstrating its commitment to innovation, accessibility, and preparing workers for the jobs of tomorrow.

Innovation in Action: Program Delivery Design

Business Engagement

PY 2024 brought about a new way of doing business with employers. Arkansas Workforce Connections absorbed a team of business managers to lead employer engagement efforts. The Arkansas Industry Connect (AIC) team is responsible for coordinating efforts in connecting employers with workforce initiatives; in conjunction with local workforce development boards, WIOA partners and business services teams. Business managers are partnering with the broader Arkansas Workforce Connections team to serve as project managers for businesses with a focus on workforce development.

With a concerted focus on matching talent with employer demand, AIC successfully began partnering with employers, training providers, and targeted populations like veterans and the underemployed to address workforce and skills gaps. Additionally, the group will focus on leveraging resources within the department to better serve employers; including providing information about workforce training funds offered through the Office of Skills Development, and other employer incentives and programs offered through the Arkansas Economic Development Commission.

Talent Pipeline Management Sector Strategy Execution

Arkansas continues to invest in employer-led workforce partnerships that align training and credentialing programs with real industry needs. In PY24, the state supported the launch of the Lithium TPM Collaborative, representing a major strategic initiative in support of Arkansas' emerging energy and advanced manufacturing sectors.

Employers in the lithium ecosystem, including extraction, processing, engineering, transportation, and advanced manufacturing, worked together to articulate shared demand for critical roles, identify required competencies, and define common hiring expectations. A collaborative partnership bringing together higher education institutions, regional K-12 school districts, workforce agencies, and sectoral intermediaries then worked together to design a responsive, high-quality talent pipeline for the industry's evolving needs. LAUNCH connects residents to career exploration resources, training programs, and jobs and supports employer talent recruitment.

The [Lithium TPM Collaborative](#) exemplifies the Governor's Workforce Strategy's emphasis on collaborative, industry-led partnerships and demonstrates how sector strategies can be tightly connected to statewide data systems, credential transparency efforts, and digital workforce tools. As the lithium industry continues to expand, the TPM Collaborative provides a model for supporting other high-growth sectors.



Industry Partnerships & Workforce Development

LITHIUMWORKS, led by The Venture Center, is a program to help build an end-to-end talent pipeline platform for Lithium employers focused on Southwest Arkansas' (SWA) communities, schools and businesses. LITHIUMWORKS' programs and platform will help the Lithium industry investing in SWA to "Hire Local" and "Buy Local."

With a design based on the U.S. Chamber's Talent Pipeline Management (TPM) principles, LITHIUMWORKS with Lithium industry support will help connect job seekers prepared by LITHIUMLEARNS to job opportunities offered by Lithium employers. LITHIUMWORKS will also work with SWA small businesses who are eager to join Lithium producers' supply chain.

Innovation in Action: Data Quality and Reporting

JOBS AND EMPLOYMENT DATA EXCHANGE (JEDX)

Arkansas continued its national leadership role as one of two states piloting the [Jobs and Employment Data Exchange \(JEDX\)](#). PY24 marked a major milestone as Arkansas moved into synthetic data pilot testing, evaluating pathways for modernizing how employment and wage data are reported, shared, and verified.

These pilots demonstrated standards-based reporting for multiple use cases including streamlined reporting, enhanced labor market information, and learning and employment record issuance (including LER-enabled resumes) that can be used to support employment verification, credential validation, eligibility and program integrity checks, and skills-based job matching. Arkansas worked closely with the U.S. Chamber of Commerce Foundation and the Bureau of Labor Statistics to refine data structures, transmission workflows, and governance models.

This work positions Arkansas to respond effectively to evolving federal requirements related to income and employment verification and underscores the state's leadership in building a modern data infrastructure capable of supporting both workforce innovation and program integrity.

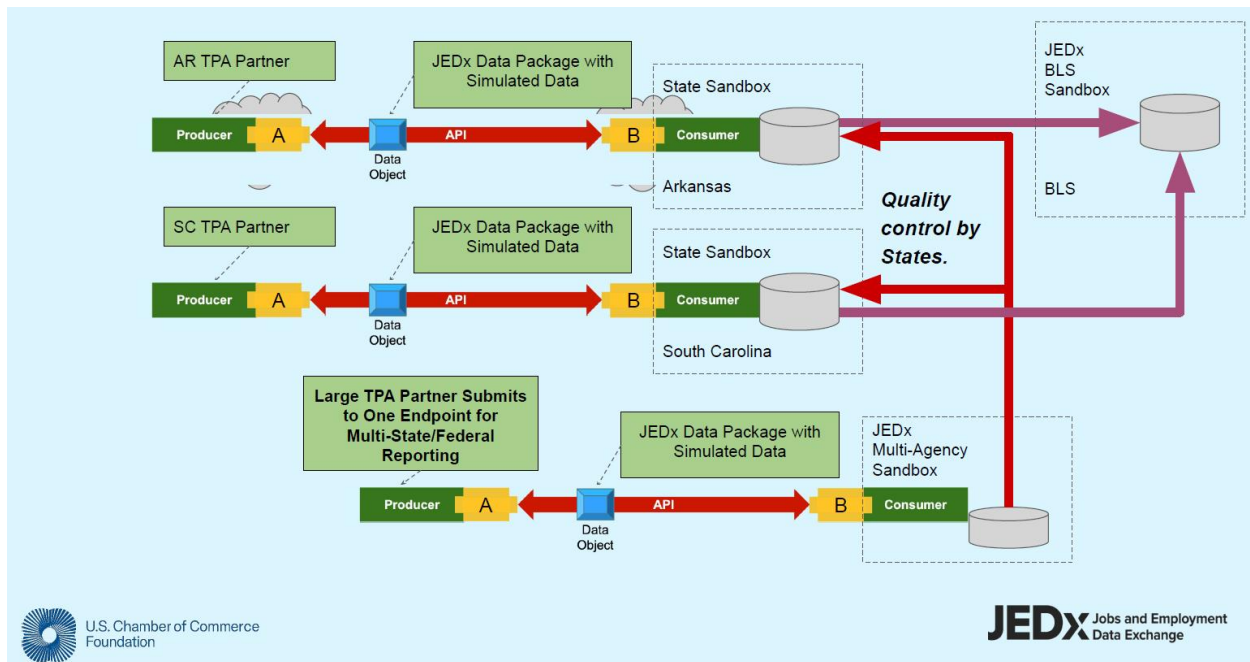

Evaluation and Research

In PY24, Arkansas received the Workforce Data Quality Initiative (WDQI) Round 10 grant, a major federal investment that strengthens the state's ability to link, analyze, and use workforce data across systems.

With WDQI Round 8 funding, Arkansas has built one of the most comprehensive cross-domain statewide longitudinal data systems in the country, giving the state comprehensive visibility into program participation and talent pipeline supply. The remaining needs supporting state strategy, policy, and practice are largely centered on improved understanding of employer demand, incorporation of new administrative data sources, enhancing credential transparency, supporting worker mobility through Learning and Employment Records (LERs), and making longitudinal data widely available through user-centered data products.

WDQI Round 10 will directly support these needs through the following objectives:

- 1. Improve Linked Workforce and Education Data:** Integrate data from the National Labor Exchange (NLX) and Talent Pipeline Management to capture timely, skill-based employer demand signals.
- 2. Enhance ETP Reporting:** Expand reporting capabilities and credential transparency (CTDL) to include labor market supply/demand alignment, measurable skill gains, and credential quality.
- 3. Promote Data-Driven Strategies and Outcomes:** Train at least 75 cross-agency and multistate staff and develop at least one multistate-scalable data product to build analytic capacity, cultivate communities of practice, and institutionalize evidence-based practices.
- 4. Design Customer-Focused Reports:** Deliver user-centered, role-based dashboards for residents, employers, providers, policymakers, workforce boards, sectoral intermediaries, and state leadership. Activate these tools and enhanced workforce data via statewide platforms (LAUNCH and CiviForm) to improve usability and integration into daily workflows.
- 5. Enhance Data Governance:** Train and support a network of workforce data stewards to support cross-agency coordination, stewardship, sharing, and active data quality management.
- 6. Develop Actionable Data Tools to Support Worker Mobility:** Scale the issuance of workforce-aligned Learning and Employment Records (LERs) and use LAUNCH to connect residents to opportunities based on verified skills, credentials, and real-time labor market signals.

The WDQI award ties together several initiatives described above, ensuring that Arkansas's workforce data infrastructure fully supports the Governor's Workforce Strategy and strengthens WIOA service delivery statewide through data-driven decision-making and evidence-based policy and practice.

[ACT Work Ready Communities](#)

[Arkansas Opens a new window](#): Regional collaboration in action

With efforts often being led by local workforce development boards, more than half of Arkansas communities participate in WRC initiatives. The Southeast Arkansas Economic Development District of 10 counties became the state's first work ready region.

Statewide, the Arkansas Economic Development Commission invests in WorkKeys Job Profiling to support businesses statewide. With over 130,000 NCRCs earned, the credential is widely available through workforce centers, high schools, and colleges.

WRC in action:

- Texarkana College and the Texarkana Chamber of Commerce integrate WorkKeys curriculum into workforce programs to prepare students for NCRC success.
- The Delta Regional Authority invested nearly \$1 million in workforce projects at Arkansas Northeastern College, Black River Technical College, and the Center on Rural Innovation — boosting training capacity and NCRC participation.
- As an ACT WorkKeys NCRC authorized testing center, Southeast Arkansas College supports communities in achieving ACT Work Ready Community status and students in earning job skill certifications. Additionally, the college collaborates with local employers by aligning job profiles with NCRC levels, ensuring the availability of a qualified and skilled workforce for training and employment opportunities.

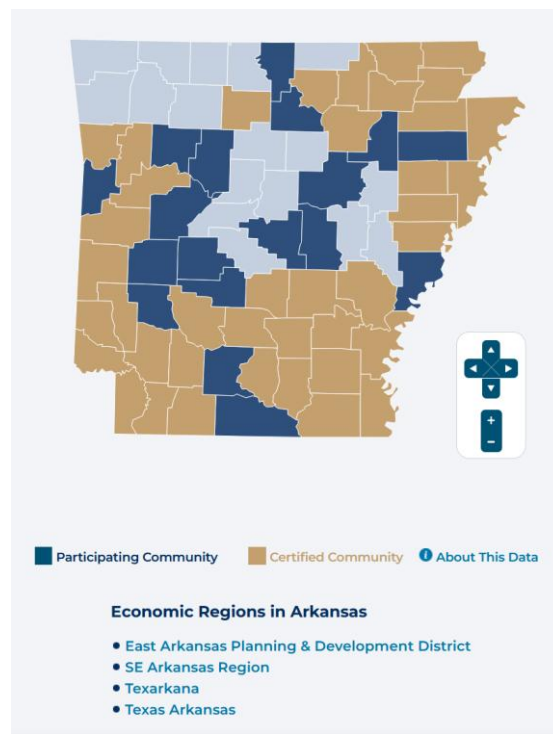

FUNDING

Governor’s Reserve/State Set Aside Funds

Arkansas continued to implement all required statewide employment and training activities in accordance with § 682.200. Statewide funds supported technical assistance, staff training, system improvements, labor market data efforts, digital modernization initiatives, and activities designed to strengthen the alignment of WIOA programs with statewide workforce and economic priorities.

Program	Allotments to State	DLW Task Force	Overview PY 2024			
			State-Level Reserve	State Administration	Statewide Activities	For Distribution to LWDAs
Youth	\$5,253,909		\$788,085	1/3 of State-level Reserve \$262,695	2/3 of State-level Reserve \$525,390	\$4,465,824
Adult	\$5,096,827		\$764,525	\$254,841	\$509,684	\$4,332,302
Dislocated Worker	\$4,522,192	\$1,130,548	\$678,329	\$226,109	\$452,220	\$2,713,315
Totals	\$14,872,928	\$1,130,548	\$2,230,939 (State Admin + Statewide Activities)	\$743,645	\$1,487,294	\$11,511,441

WIOA Outreach Activities Awards

Arkansas Workforce Connections continued efforts to increase awareness of WIOA-funded programs and services by providing additional outreach funds to Local Workforce Development Boards.

These awards assisted local workforce areas in expanding communications, reach underserved populations, and strengthen connections between jobseekers, employers, and the workforce system. Funds were used for allowable outreach activities. The goal of these investments was to support stronger enrollments and greater public awareness of the services available through the Arkansas Workforce Centers.

Arkansas JobLink (AJL)

Arkansas JobLink (AJL) is the state’s integrated, web-based workforce development management information system used by state and local partners to deliver services, manage case records, and support performance reporting for WIOA Title I, WIOA Title III, and the Trade Adjustment Assistance program.

AJL enables jobseekers, employers, and staff to access job matching, labor exchange, reemployment services, and case management information through a single coordinated system.

All workforce programs use AJL to view and document services, helping reduce duplication, improve communication among partner programs, and create a comprehensive record of each participant’s engagement across the workforce system. This integrated approach also ensures that performance reporting reflects a complete and accurate view of participant outcomes.

Arkansas continues to prioritize technology improvements that streamline participation and reduce barriers for jobseekers. In PY 2024, the state implemented a new API connection between Civiform, enabling automatic registration into AJL for individuals who create a Civiform account and meet eligibility for Wagner–Peyser (Title III) services. This enhancement mirrors the existing automated interface between the Unemployment Insurance system and AJL, reducing the need for manual registration and ensuring jobseekers are connected quickly to reemployment and career services.

AJL also integrates quarterly wage data to allow the state to track performance indicators, including employment and earnings outcomes. Wage information is regularly matched using state wage records and the Wage Record Interchange System (WRIS), enabling Arkansas to measure outcomes for individuals who obtain employment both within and outside the state. Local WIOA Title I service providers also use AJL wage data to monitor local performance and support continuous improvement.

AJL remains a central component of Arkansas’s workforce system, supporting service delivery, performance accountability, and coordinated case management across all WIOA core programs and partner agencies.

All WIOA Title I service providers have access to wage information for the purpose of evaluating local performance. AJL can be accessed at <https://www.arjoblink.arkansas.gov>

Rapid Response

Rapid Response is a proactive and business-focused service designed to help companies and workers navigate layoffs or closures with minimal disruption. The state’s Rapid Response team provides early intervention, on-site assistance, and coordinated services to workers affected by layoffs while helping employers understand available layoff-aversion strategies.

Rapid Response services are delivered in partnership with the Arkansas Workforce Centers. Assistance to workers may include résumé development, job search support, interviewing workshops, career counseling, and training opportunities. Employers may receive information on incumbent worker training, shared work options, and strategies to minimize the impact of layoffs.

The state’s Dislocated Worker program also manages a fleet of Mobile Workforce Centers, which are equipped with computers, internet access, printers, and ADA-accessible technology. These units can be deployed to provide immediate support to workers and communities experiencing layoffs.

In PY ’24 the team provided Rapid Response Services to 22 companies who reported actual or anticipated layoffs or closures impacting over 2,110 workers.

Disaster Grants

During program year 2024, no DWGs were administered by the state of Arkansas, however several local areas were impacted by a disaster early in Spring 2025. The state applied for and received funding for disaster recovery efforts, which will be carried out in PY25.

Discretionary Grants

USDOE ReImagine Workforce grant

Arkansas Workforce Connections continued to administer the Reimagine Arkansas Workforce Project. The program, funded by the United States Department of Education, provides funding for qualifying individuals to complete online training at no cost in order to meet workforce needs across the state.

The U.S. Department of Education awarded a grant worth over \$13 million to the Arkansas Workforce Development Board and the Arkansas Division of Workforce Services to fund the Reimagine Arkansas Workforce Project. Project partners include state agencies, U of A Global Campus Professional and Workforce Development, Shorter College, and iDatafy LLC.

While the grant ended in September 2025, the partners served over 3,000 Arkansans who were unemployed, underemployed, new to the workforce and/or have no work history, are a member of an underrepresented population, receive public assistance, reside in rural areas, are a veteran, are the spouse of a veteran, are homeless, are 55 years of age or older, previously incarcerated, have been paroled, or are are categorized with individuals with barriers to employment.

PERFORMANCE ACCOUNTABILITY

PY '24 Outcomes



The Arkansas Workforce Development Board (AWDB) and state agency partners continuously assess the performance outcomes of the workforce system in annual performance and benchmark reports.

The state agency responsible for each of the core programs outlined in program-specific areas regularly assesses performance accountability measures at the state, regional and local levels as required by each core program. At the completion of each program year, each core WIOA partner presents its annual performance to the State Workforce Board.

To support the effort of ensuring that one-stop program partners are well-positioned to meet the performance accountability requirements of WIOA, the WIOA Roundtable's Program Performance Committee focuses on coordinating core partners to ensure systems have the capacity to collect and report required new and updated data elements under WIOA, as well as capacity to track aggregate data for performance indicators applicable to all four core partners was established.

The state and local areas are assessed based on a comparison of the actual performance level with the adjusted level of performance each quarter and annually. Universal definitions will be utilized to determine if a core program exceeded, met, or failed to meet the negotiated levels of performance.

Performance outcomes for WIOA Titles I & III programs are included in the following charts:



WIOA TITLE I-B

YOUTH

Title I Statewide Youth	PY 2024
Total Participants Served	524
Total Participants Exited	297

Measure	Number of Participants in Cohort	Number of Participants Achieving Outcome	90% of Negotiated Rate	Negotiated Rate	Actual	Status
2nd Qtr. Employment	320	228	68.9%	76.60%	71.25%	Passed
2nd Qtr. Median Earnings	320	228	\$3,555	\$3,950	\$4,516	Exceeded
4th Qtr. Employment	391	279	69.3%	77.00%	76.41%	Passed
Credential Attainment	214	115	52.2%	58.00%	53.74%	Passed
Measurable Skills Gain	179	128	59.3%	65.90%	71.51%	Exceeded

17

WIOA TITLE I-B

PY 24 LWDB PERFORMANCE RESULTS

YOUTH

	Youth Employment Q2 Rate	Youth Employment Q4 Rate	Youth Median Earning	Youth Credential Attainment Rate	Youth Measurable Skill Gains
PY2024 Performance Negotiated Statewide	76.60%	77.00%	\$3,950.00	58.00%	65.90%
PY2024 Performance Actual Statewide	71.25%	76.41%	\$4,516.00	53.74%	71.51%
Central	77.78%	80.00%	\$5,857.00	100.00%	100.00%
City of Little Rock	88.24%	66.67%	\$1,776.00	70.00%	72.22%
Eastern	93.75%	93.10%	\$6,760.00	90.00%	86.21%
North Central	63.64%	65.79%	\$3,552.00	58.33%	74.42%
Northeast	75.00%	70.73%	\$3,375.00	50.00%	53.85%
Northwest	75.00%	82.22%	\$3,435.00	76.32%	88.46%
Southeast	65.96%	61.40%	\$3,239.00	2.33%	66.67%
Southwest	72.73%	84.21%	\$7,050.00	66.67%	44.44%
West Central	56.00%	53.13%	\$4,104.00	45.83%	55.00%
Western	67.39%	76.19%	\$7,755.00	71.43%	42.86%

WIOA TITLE I-B



ADULT

Title I Statewide Adult	PY 2024
Total Participants Served	674
Total Participants Exited	435

Measure	Number of Participants in Cohort	Number of Participants Achieving Outcome	90% of Negotiated Rate	Negotiated Rate	Actual	Status
2nd Qtr. Employment	530	419	72.9%	81.0%	79.1%	Passed
2nd Qtr. Median Earnings	530	419	\$6,975	\$7,750	\$7,750	Passed
4th Qtr. Employment	670	523	71.1%	79.0%	78.1%	Passed
Credential Attainment	477	353	65.7%	73.0%	74.0%	Exceeded
Measurable Skills Gain	381	314	66.3%	73.7%	82.4%	Exceeded

WIOA TITLE I-B



PY 24 LWDB PERFORMANCE RESULTS

ADULT

	Adult Employment Q2 Rate	Adult Employment Q4 Rate	Adult Median Earning	Adult Credential Attainment Rate	Adult Measurable Skill Gains
PY2024 Performance Negotiated Statewide	81.00%	79.00%	\$7,750.00	73.00%	73.70%
PY2024 Performance Actual Statewide	79.10%	78.10%	\$7,750.00	74.00%	82.40%
Central	70.60%	81.60%	\$10,470.00	85.00%	95.00%
City of Little Rock	92.10%	88.60%	\$6,703.00	84.90%	83.80%
Eastern	87.10%	94.00%	\$7,040.00	93.80%	82.90%
North Central	76.80%	71.40%	\$7,339.00	70.60%	92.50%
Northeast	84.50%	87.70%	\$6,349.00	85.70%	90.80%
Northwest	89.70%	84.60%	\$10,097.00	75.40%	92.90%
Southeast	56.80%	61.30%	\$6,560.00	23.90%	55.40%
Southwest	72.90%	72.90%	\$7,336.00	88.10%	100.00%
West Central	83.90%	74.60%	\$8,371.00	66.70%	81.80%
Western	86.50%	70.30%	\$9,021.00	73.40%	64.50%

WIOA TITLE I-B



DISLOCATED WORKER

Title I Statewide DLW	PY 2024
Total Participants Served	100
Total Participants Exited	64

Measure	Number of Participants in Cohort	Number of Participants Achieving Outcome	90% of Negotiated Rate	Negotiated Rate	Actual	Status
2nd Qtr. Employment	83	64	74.7%	83.00%	77.11%	Passed
2nd Qtr. Median Earnings	83	64	\$8,280	\$9,200	\$7,140	Failed
4th Qtr. Employment	103	80	74.7%	83.00%	77.67%	Passed
Credential Attainment	81	68	67.5%	75.00%	83.95%	Exceeded
Measurable Skills Gain	60	52	68.0%	75.60%	86.67%	Exceeded

33

WIOA TITLE I-B



PY 24 LWDB PERFORMANCE RESULTS

DISLOCATED WORKER

	Dislocated Worker Employment Q2 Rate	Dislocated Worker Employment Q4 Rate	Dislocated Worker Median Earning	Dislocated Worker Credential Attainment Rate	Dislocated Worker Measurable Skill Gains
PY2024 Performance Negotiated Statewide	83.00%	83.00%	\$9,200.00	75.00%	75.60%
PY2024 Performance Actual Statewide	77.11%	77.67%	\$7,140.00	83.95%	86.67%
Central	70.00%	85.00%	\$3,847.00	80.00%	90.91%
City of Little Rock	66.67%	61.54%	\$7,629.00	90.00%	80.00%
Eastern	100.00%	100.00%	\$7,280.00	100.00%	100.00%
North Central	76.84%	71.43%	\$7,339.00	70.59%	92.45%
Northeast	88.89%	83.33%	\$6,225.00	100.00%	100.00%
Northwest	60.00%	88.89%	\$10,665.00	82.35%	87.50%
Southeast	0.00%	42.86%	\$0.00	50.00%	100.00%
Southwest	76.92%	90.90%	\$11,068.00	100.00%	77.78%
West Central	100.00%	77.78%	\$7,000.00	100.00%	0.00%
Western	75.00%	55.56%	\$6,877.00	66.67%	88.89%

34

WIOA TITLE III- Wagner Peyser



PY 24 STATEWIDE PERFORMANCE RESULTS

WAGNER PEYSER

Title III Statewide Wagner Peyser	PY 2024
Total Participants Served	55,556
Total Participants Exited	54,906

Measure	Number of Participants in Cohort	Number of Participants Achieving Outcome	90% of Negotiated Rate	Negotiated Rate	Actual	Status
2nd Qtr. Employment	54,380	37,766	63.7%	70.80%	69.45%	Passed
2nd Qtr. Median Earnings	54,380	37,766	\$6,215	\$6,905	\$7,403	Exceeded
4th Qtr. Employment	57,106	39,670	63.1%	70.10%	69.47%	Passed

57

Arkansas performed well and met or exceed all performance targets with the exception of the dislocated worker 2nd quarter median earnings measure. The state continues to face unique economic and workforce challenges that directly impact the median earnings of dislocated workers in the second quarter after program exit. While the state has made significant strides in workforce integration and service delivery, several structural and regional factors have constrained earnings outcomes.

Key Challenges in Arkansas

- Industry Composition & Wage Levels
- Arkansas’s economy is heavily concentrated in agriculture, manufacturing, and service sectors, which traditionally offer lower median wages compared to national benchmarks.
- Dislocated workers often transition into available jobs that are entry-level or seasonal, limiting wage growth in the short term.
- Rural Workforce Dynamics
- A majority of Arkansas counties are rural, with limited access to high-wage employment opportunities.
- Geographic barriers, transportation challenges, and fewer large employers in rural areas reduce the ability of dislocated workers to secure higher-paying positions within the second quarter after exit.
- Economic Shifts & Layoff Patterns
- Arkansas has experienced sector-specific layoffs (e.g., retail closures, manufacturing downsizing) that disproportionately affect mid-skill workers.
- Many dislocated workers re-enter the labor market at lower wages due to industry mismatch between prior experience and current demand.
- Training & Credential Lag
- Earnings outcomes improve in later quarters, but the timing of the measure captures workers before they fully benefit from training investments.
- Cost of Living & Wage Structures
- Even when employment is secured, median earnings remain below national averages, affecting performance outcomes despite successful reemployment.

Forward Strategy- To address these challenges, Arkansas is:

- Expanding partnerships with emerging industries (healthcare, IT, advanced manufacturing) to connect dislocated workers to higher-wage opportunities.
- Enhancing career pathways and apprenticeship programs to accelerate wage growth beyond entry-level positions.
- Leveraging LAUNCH and Civiform integration to streamline service delivery and improve alignment between training and employer demand.
- Increasing focus on long-term earnings measures to better reflect the impact of workforce investments beyond the second quarter.

Policies

Common Exit

Arkansas maintains a Common Exit policy requiring a unified date of exit for participants served across WIOA Title I, Title III, and the Trade Adjustment Assistance (TAA) programs. In alignment with ETA guidance, any participant enrolled or co-enrolled in one or more of these programs remains an active participant in all applicable programs until no services have been received in any of them for 90 consecutive days. When 90 days have passed with no service in any Common Exit program, the participant exits all programs simultaneously, with the exit date retroactively applied to the date of the last service received in any program.

Data Validation Policy

In accordance with WIOA Title I-B Policy 4.6, the state provides annual data validation training to both state and local staff. Local Workforce Development Boards are required to conduct their own annual training as well. These trainings review validation procedures, common trends, and issues identified during monitoring. During annual monitoring reviews, state staff verify that local boards are implementing data validation requirements consistently and accurately.

Effectiveness in Serving Employers

WIOA includes a pilot performance indicator designed to assess effectiveness in serving employers. States are asked to report on two of the three federal measures and may include a state-defined measure. Arkansas continues to report on the following indicators:

- I- Retention with the Same Employer
- II- Employer Penetration

These measures help evaluate how well the workforce system supports employers in finding, developing, and retaining talent.

Evaluation/Customer Satisfaction

Arkansas continues to build upon the results of the most recent evaluation conducted by an external firm. The agency is currently evaluating a focus for a new PY 25 evaluation that will be derived from guidance from the state workforce board, reflecting priorities included in the WIOA Combined State Plan two-year modification.

The University of Arkansas Counselor Education Program completed a comprehensive WIOA Systems Evaluation, Skills Gap Analysis, and a series of Customer Service Surveys.

Results of the evaluation, including customer satisfaction findings can be found [here](#). The Arkansas Workforce Development Board, in conjunction with state staff are collaboratively reviewing the report and addressing deficiencies and gaps while also improving areas that were noted as promising practices.

Additionally, several local workforce development boards and One-Stop Operators have adopted their own assessments to gauge customer satisfaction in their regions.

CHALLENGES & NEEDS

Waivers

Arkansas's workforce system currently operates under several USDOL-approved waivers that provide flexibility in delivering WIOA programs. These waivers have helped local boards respond more effectively to regional needs, but additional flexibility is still required to fully align services with the state's economic priorities. By granting Arkansas more waivers, USDOL would enable workforce leaders to innovate further—expanding access to career pathways, tailoring supportive services, and reducing administrative barriers. In short, while existing waivers have been valuable, more are needed to empower Arkansas to carry out workforce programs with the agility and responsiveness that today's labor market demands.

Current Waivers

Waiver of 20 CFR 681.550 to allow WIOA individual training accounts (ITAs) for in-school youth (ISY).

ETA approves, for Program Year (PY) 2024 and 2025, the State's request to waive the requirement limiting ITAs to only out-of-school youth (OSY), ages 16–24. In addition to these OSY, the State may use ITAs for ISY, ages 16–21. ETA reviewed Arkansas' waiver request and plan and has determined that the requirements requested to be waived impede the ability of Arkansas to implement its plan to improve the workforce development system. Approval of this waiver should not impede Arkansas' efforts to prioritize OSY, including outreach to the OSY population.

Waiver associated with the requirement at WIOA Section 129(a)(4)(A) and 20 CFR 681.410 that the State and local areas expend 75 percent of Governor’s reserve youth funds and local formula youth funds on OSY.

ETA approves for PY 2024 and PY 2025, which includes the entire time period for which states are authorized to spend each of those Program Year fund allotments, Arkansas’ request to waive the requirement that the State expend 75 percent of Governor’s reserve youth funds on OSY. ETA reviewed Arkansas’ waiver request and plan and has determined that the requirements requested to be waived impede the ability of the State to implement its plan to improve the workforce development system. Arkansas may lower the expenditure requirement of Governor’s reserve funds to 50 percent for OSY.

In addition, ETA approves for PY 2024 and PY 2025, which includes the entire time period for which local areas are authorized to spend each of those Program Year fund allotments, Arkansas’ request to waive the requirement that local areas expend 75 percent of local youth formula funds on OSY. Arkansas may lower the local youth funds expenditure requirement to 50 percent for OSY. As a result of this waiver, ETA expects that the number of ISY served will increase, and performance accountability outcomes for overall WIOA Youth (including both ISY and OSY) will remain steady or increase for the majority of the WIOA Youth performance indicators. Arkansas is also approved to calculate the lowered 50 percent expenditure rate at the State level instead of individually for each local area.

End Report

APPENDIX

APPENDICE I: SUCCESS STORIES



Lervae Williams, a motivated young adult from rural Eastern Arkansas, enrolled in the WIOA Youth Program in January 2025 with a clear goal: to build stability and create a better future for himself. As a low-income, unemployed youth living in a single-parent household, and as someone self-identified as an ex-offender, he faced multiple barriers to entering the workforce. Yet from the moment he connected with the program, it was evident that he possessed a strong determination to change the direction of his life.

Lervae’s journey into WIOA was inspired by someone close to him—his mother, Bliss Ross—who had previously participated in WIOA and successfully transitioned into a meaningful career. Watching her overcome obstacles and secure employment through the support of the Arkansas Workforce System encouraged him to pursue his own path toward long-term success.

After completing his application and eligibility documentation at the Forrest City Workforce Center, Lervae began working closely with his Career Advisor to complete an Individual Service Strategy (ISS). Together, they identified his long-term interests, including coaching, personal training, and recreation, and aligned these aspirations with local labor market needs. Through this process, he received job search assistance, labor market information on growing occupations, and guidance on work readiness and career development. His Career Advisor also helped him explore hands-on learning opportunities through the WIOA Work Experience Program.

On February 14, 2025, Lervae actively engaged in job search activities and submitted multiple applications. His persistence and professionalism caught the attention of staff, and his Career Advisor was able to directly connect him with a recruiter at the East Arkansas Regional Division of Correction’s Brickey’s Unit. Within just a few weeks, Lervae was offered a full-time position as a Correction Officer.

Lervae began employment on March 3, 2025, earning \$23.17 per hour at 40 hours per week—a transformative change for his financial stability and long-term goals.

Two weeks later, he met again with his Career Advisor to review labor market trends in the correctional field and discuss advancement pathways in the broader criminal justice system.

With a renewed sense of purpose, he now views his job as both a career foundation and a steppingstone toward future leadership roles.

Today, Lervae credits the WIOA Youth Program for providing the structure, encouragement, and support he needed to overcome personal and systemic barriers. His story not only reflects an individual success, but also demonstrates how WIOA services can uplift entire families across generations. His achievements stand as a testament to the impact of Arkansas's workforce programs and the potential unlocked when job seekers receive the right tools at the right time.



Alexander Wilson first connected with Workforce Innovation and Opportunity Act (WIOA) staff on December 30, 2024, when he met with his Career Advisor to explore eligibility for the WIOA Youth Program. At the time, he was enrolled at the Cass Job Corps Civilian Conservation Center and was eager to build real-world work experience that would support his long-term career goals. After meeting the eligibility requirements, Alexander was placed in a paid WIOA work experience position on campus, where he worked from December 30, 2024, through September 15, 2025. Throughout his work experience, Alexander

demonstrated exceptional commitment and a strong work ethic. In addition to his daily responsibilities, he enrolled in the Heavy Equipment Operator program at Cass, where he received hands-on training in equipment operation and safety. His determination paid off—he successfully completed the WIOA work experience, earned an OSHA-10 certificate, and gained specialized heavy equipment training that positioned him for long-term success in the construction and skilled trades industries.

Alexander also used his time in the program to strengthen his financial independence. By consistently saving a portion of his earnings, he was able to purchase reliable transportation—a 2019 Chevrolet Silverado—which expanded his ability to travel for work and training opportunities and opened the door to more job prospects.

Alexander's hard work, combined with the guidance and support of the WIOA Youth Program, led to an impressive outcome: after completing his program at Cass Job Corps and his WIOA Youth services, he secured full-time employment with P & E Construction as a forklift operator, earning \$42.00 per hour. With a solid foundation of skills, credentials, and practical experience, Alexander is already planning his next step—beginning an apprenticeship program in January 2026 to continue advancing in his career.

Alexander’s journey reflects how targeted support, combined with personal determination, can change the trajectory of a young person’s future.

His success serves as an inspiring example of how the WIOA Youth Program equips emerging workers with the tools they need to achieve meaningful, long-term economic stability.



Daytona Oldham came to the Northwest Arkansas Workforce Development Area with a clear goal: to continue her education and earn a credential that would lead to a stable, high-wage career. After completing her prerequisites for the Registered Nursing program at Northwest Arkansas Community College (NWACC), she was accepted into the cohort beginning in August 2022. At the time, Daytona was a low-income student relying on SNAP benefits and unable to work while enrolled in the rigorous program. Although she possessed a high school diploma and some college experience, she lacked the occupational skills credentials needed to secure self-sustaining employment in the healthcare field.

Through the WIOA Title I-B Adult Program, Daytona received critical support that allowed her to persist in the program and focus on her training. Assistance included essential items such as a laptop, tablet, uniforms, books, CPR training, background checks, transportation support, and coverage for testing fees, including the NCLEX exam and state licensing. She was also referred to — and later awarded — an Upskill NWA scholarship, which paid her full tuition and most program-related fees, easing the financial strain of attending school full-time.

Daytona excelled in the program and completed her Associate of Applied Science in Nursing on schedule in May 2024. She passed the NCLEX exam in July 2024, earning her RN license and officially entering the nursing profession. Shortly afterward, she accepted a Registered Nurse position with Washington Regional Medical Center in Fayetteville, Arkansas, beginning August 12, 2024, at a starting wage of \$31.00 per hour.

Daytona’s journey reflects the combined impact of WIOA supportive services, community partnerships, and her own determination. With the right guidance, resources, and training, she transformed her career prospects and achieved a meaningful, in-demand occupation in the healthcare sector.

**WORKFORCE INNOVATION & OPPORTUNITY ACT
(WIOA)**

**ARKANSAS
WORKFORCE CONNECTIONS**

A DIVISION OF ARKANSAS DIVISION OF WORKFORCE SERVICES

**ANNUAL
REPORT**

PY 2024



ARKANSAS WORKFORCE CENTERS
Bringing People and Jobs Together.